

11.2 Technical data and options

AMSA 3L Size 45

AMSA 3L S 45 Drawings

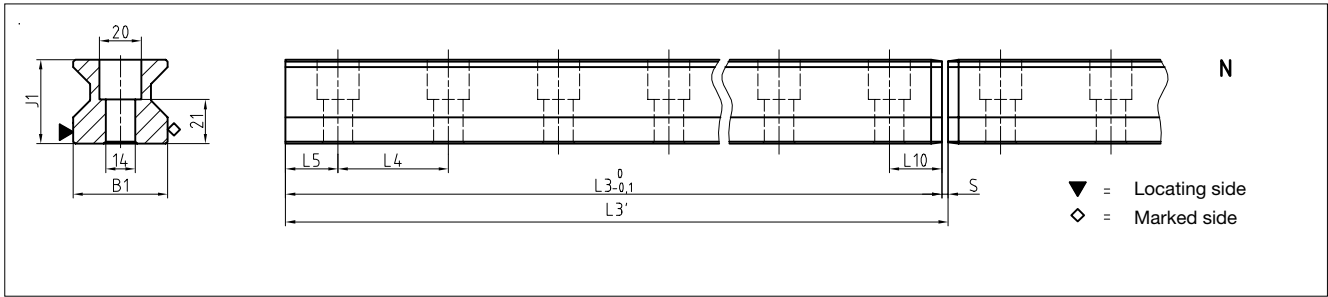

AMSA 3L W 45 Drawings

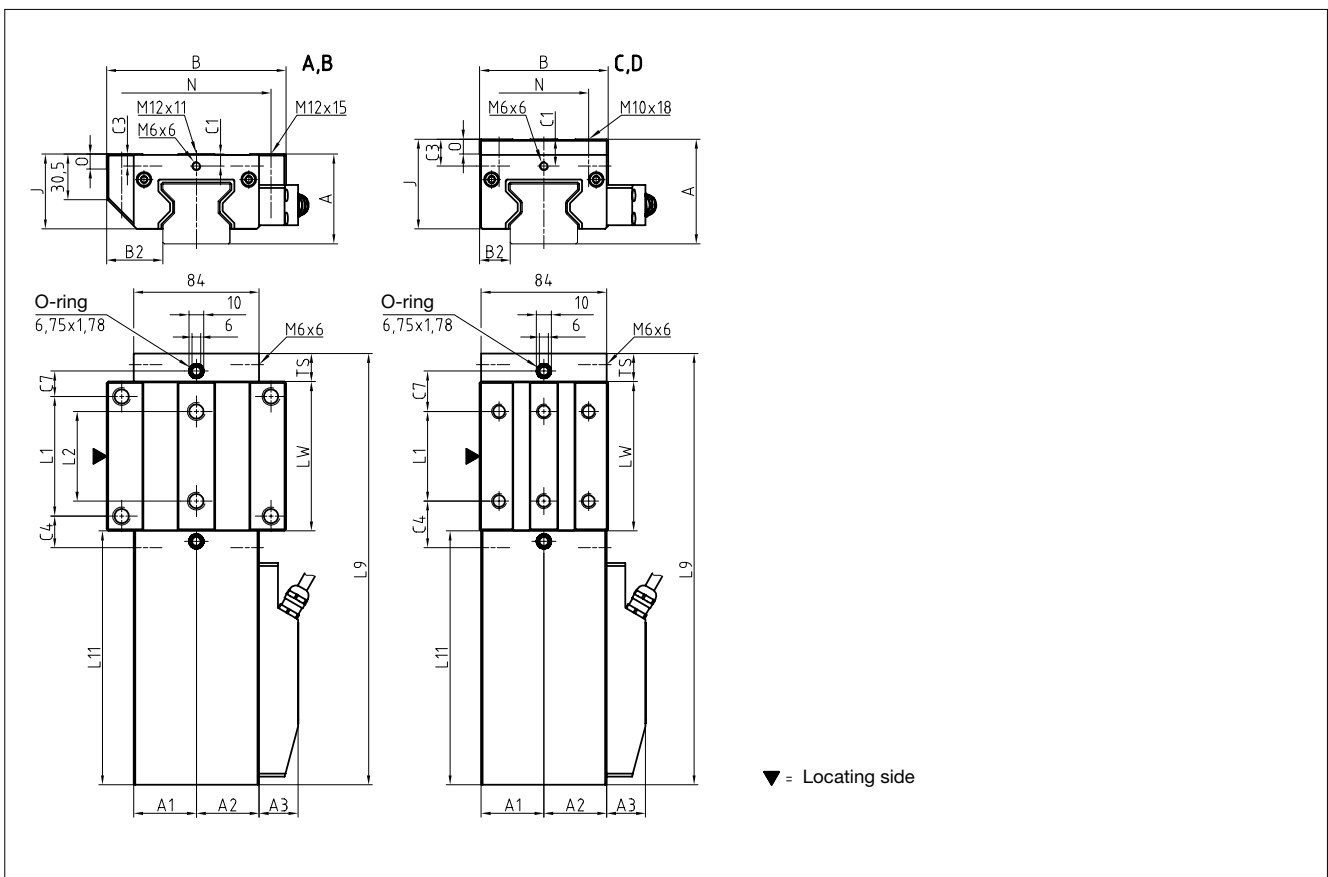

AMSA 3L W 45 Rigidity diagram

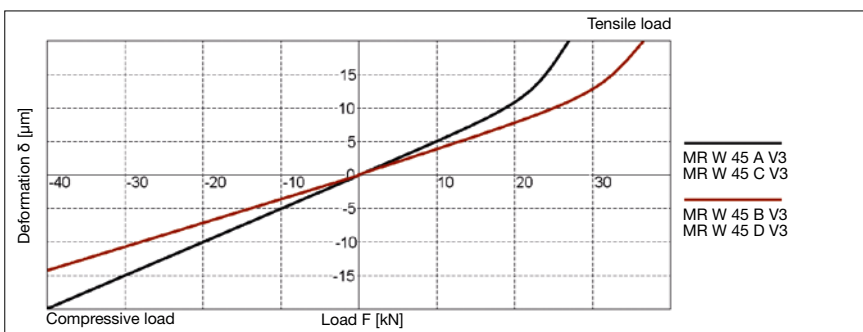

AMSA 3L W 45 Load rating

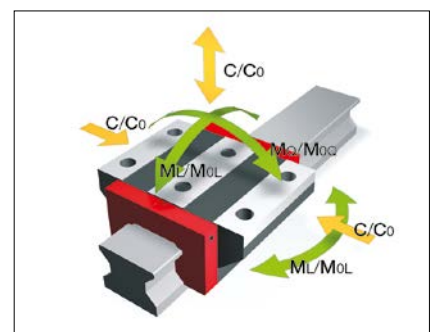

11.2 Technical data and options

AMSA 3L Size 45

AMSA 3L S 45 Dimensions

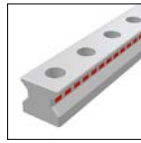

		AMSA 3L S 45-N			
B1:	Rail width	45			
J1:	Rail height	39.95			
L3:	Rail length	2992			
L3':	System length	2992.5			
S:	Gap size	0.5			
L4:	Spacing of fixing holes	52.5			
L5/L10:	Position of first/last fixing hole	26			
Gew.:	Rail weight, specific (kg/m)	10.8			

Available options for AMSA 3L S 45



AMSA 3L W 45 Dimensions and capacities



	AMSA 3L W 45-A	AMSA 3L W 45-B	AMSA 3L W 45-C	AMSA 3L W 45-D		
A:	System height	60	60	70	70	
A1:	Half width of housing on opposite side	42	42	42	42	
A2:	Half width of housing on reading head side	42	42	42	42	
A3:	Projection of reading head	26	26	26	26	
B:	Carriage width	120	120	86	86	
B2:	Distance between locating faces	37.5	37.5	20.5	20.5	
C1:	Position of center front lube hole	8	8	18	18	
C3:	Position of lateral lube hole	8	8	18	18	
C4:	Position of lateral lube hole	21.5	38.75	31.25	38.75	
C7:	Position of top lube hole	17	34.5	27	34.5	
J:	Carriage height	50	50	60	60	
L1:	Exterior fixing hole spacing	80	80	60	80	
L2:	Interior fixing hole spacing	60	60	-	-	
L9:	Carriage length with housing	288.7	323.7	288.7	323.7	
L11:	Housing length	169.9	169.9	169.9	169.9	
Lw:	Inner carriage body length	100	135	100	135	
N:	Lateral fixing hole spacing	100	100	60	60	
O:	Reference face height	10	10	10	10	
Ts:	Front plate thickness	18.8	18.8	18.8	18.8	

Capacities and weights

C0:	Static load capacity (N)	167500	229500	167500	229500	
C100:	Dynamic load capacity (N)	93400	127800	93400	127800	
MOQ:	Static cross moment capacity (Nm)	4621	6333	4621	6333	
MOL:	Static longitud. moment capacity (Nm)	2790	5161	2790	5161	
MQ:	Dyn. cross moment capacity (Nm)	2577	3527	2577	3527	
ML:	Dyn. longitud. moment capacity (Nm)	1556	2874	1556	2874	
Gew:	Carriage weight (kg)	4.4	5.5	4.2	5.2	

Available options for AMSA 3L W 45

